

28

# NAVCO

Safe & Lock Company

943 W. 7th Ave. • Corsicana, TX 75110 • TDPS No. B13118  
Ofc(903) 874-3522 • F(903) 874-1715 • navco@swbell.net

Navco Safe and Lock Company  
943 W 7TH AVE  
CORSICANA, TX 75110  
(903)874-3522  
navcolock@gmail.com

**BILL TO**  
Navarro County  
601 N. 13th St, Su 6  
Corsicana, TX 75110

**RECEIVED**

FEB 22 2022

NAVARRO COUNTY  
AUDITOR'S OFFICE

INVOICE Y021801

DATE 02/18/2022 TERMS Net 30

DUE DATE 03/20/2022

DATE	ACTIVITY	QTY	RATE	AMOUNT
	Code Key Key cut by code	1	25.00	25.00T

Terms: We do accept Visa, MasterCard, and Discover Credit Cards. Net is due at 30 days. There will be a 2% rate (24% APR) charged on all balances over 20 days old, and a \$20 monthly late charge on any balance over 30 days old.

SUBTOTAL	25.00
TAX	0.00
TOTAL	25.00

TOTAL DUE \$25.00

*Denis Putina*  
2-18-22

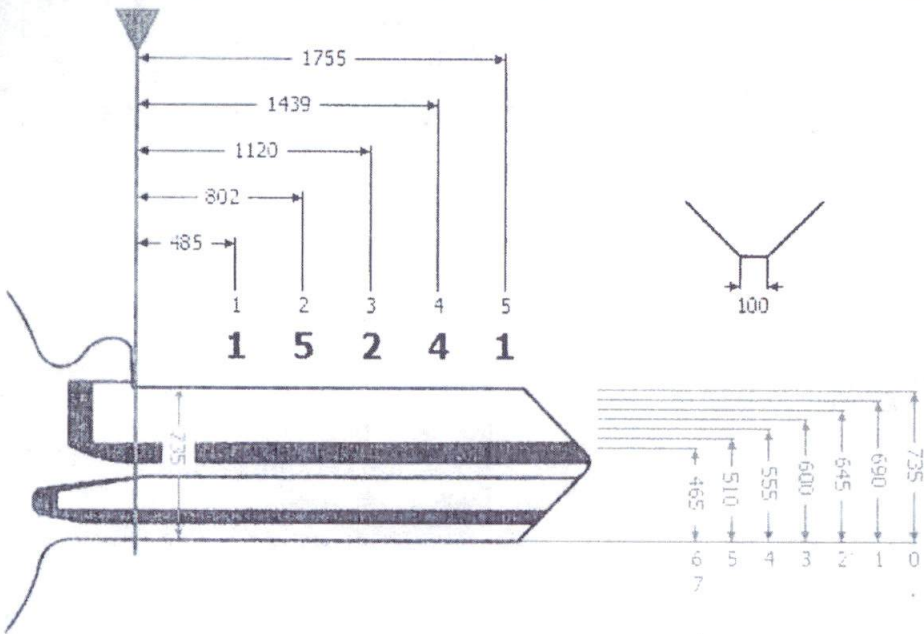

Key blanks

Hudson	H20
Alba	HL2
Axxess	92
Curtis	CO106

Machine data

HPC Blitz card: C26

Code **310E**

Bitting **15241**



RECEIVED

FEB 22 2022

NAVARRO COUNTY AUDITOR'S OFFICE

NAVARRO COUNTY AUDITOR'S OFFICE

300 W 3rd Ave, Suite 6  
Corsicana, Texas 75110  
e-mail: auditor@navarrocounty.org

Natalie Robinson, First Assistant,  
Kaye Martin, Assistant  
Lisa Clay, Assistant  
Patty Wells, Assistant  
Jan Wise, Administrative Assistant

Terri Gillen, County Auditor

Phone: (903) 654-3095

Fax: (903) 654-3097

INTEROFFICE MEMO

The attached item is being returned for the following reasons:

- Item incurred before purchase order issued
- Purchase order number is inconsistent with invoice
- Amount billed does not match the purchase order
- Vendor on purchase order does not match invoice
- Insufficient documentation to process payment
- Signature or date not present
- Budget Account Number (Line Item) is missing – Acct # \_\_\_\_\_
- Insufficient budget
- Payment Request inconsistent with County Policy
- Other \_\_\_\_\_

Please provide the additional documentation or explanation necessary to process this payment request. This notice must remain attached to the payment request.

Additional explanation: NAVCO SAFE Invoice YD21801

The Department Head or Elected or Appointed Official must sign this form confirming notification that the Navarro County Purchasing Policy was not followed on this purchase.

Jerry Putman  
Signature

2-22-22  
Date